

Air Motors

Technical Guide



People.
Passion.
Performance.



Chicago
Pneumatic

AIR MOTORS

Technical Guide



**Chicago
Pneumatic**

Contents

| | |
|--|-----------|
| 1. INTRODUCING THE AIR MOTOR | 4 |
| Compact and lightweight | 4 |
| Torque increases with load | 4 |
| Steplessly adjustable power output | 4 |
| Undamaged by overloads | 5 |
| Ideal in hazardous and hostile environments | 5 |
| Easily reversed | 5 |
| Simple to install | 5 |
| Rugged | 5 |
| 2. DESIGN AND WORKING PRINCIPLE | 6 |
| Design | 6 |
| Working principle | 7 |
| Clockwise/counter clockwise/ reversible | 7 |
| Rotor speed | 8 |
| Number of vanes | 8 |
| Gears | 9 |
| Lubrication free motors | 9 |
| Motors with brakes | 9 |
| 3. THE PERFORMANCE OF AN AIR MOTOR | 10 |
| The power curve | 11 |
| The working point | 11 |
| Air consumption | 11 |
| Starting torque | 12 |
| Stall torque | 12 |
| 4. THE USE OF GEAR UNITS | 13 |
| 5. SHAFT LOADING | 14 |
| 6. METHODS OF MODIFYING MOTOR PERFORMANCE | 15 |
| Throttling | 15 |
| Pressure regulation | 16 |
| 7. USING CATALOGUE PERFORMANCE DATA | 17 |
| 8. HOW TO CHOOSE THE RIGHT MOTOR | 18 |
| General rules for selecting air motors | 18 |
| Service life | 21 |
| Air consumption | 22 |
| Shaft loading | 23 |
| 9. SILENCING | 24 |
| 10. INSTALLING YOUR AIR MOTOR | 25 |
| Air lines | 25 |
| Air preparation | 27 |
| Lubrication | 27 |
| Directional control valves | 28 |
| Installation examples | 28 |
| APPENDIX | 29 |
| Planetary gears | 29 |
| Helical gear | 29 |



1. Introducing the air motor

The air motor is one of the toughest and most versatile power units available to the design engineer.

The features and characteristics of the air motor make it the natural choice of power for industrial applications, present and future.

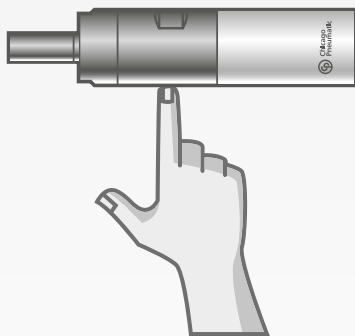

Compact and lightweight

An air motor weighs only 1/4 as much as an electric motor with the same output and occupies only 1/6 of the space. Air motors develop far more power in relation to their size and weight than most other motor types.

Torque increases with load

The output of an air motor is relatively constant within a wide speed range – when an increase in load lowers the speed the torque increases.

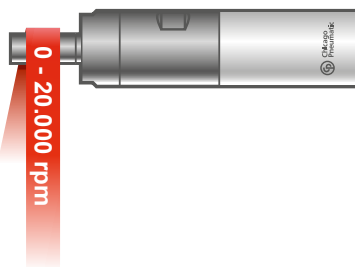
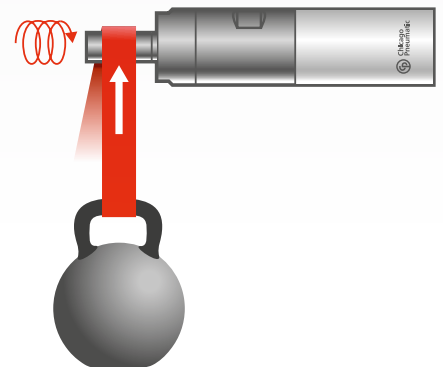
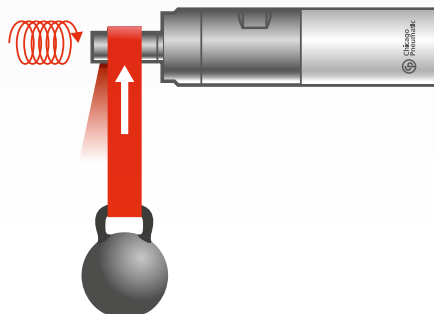

Steplessly adjustable power output

The torque and output of an air motor can be adjusted steplessly by varying the working pressure. Moreover, speed can be adjusted steplessly throughout its entire range by varying the air flow.

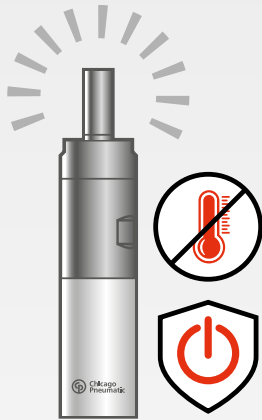

Undamaged by overloads

Air motors can be stalled indefinitely without overheating or sustaining any other type of damage. They can also be started and stopped repeatedly without limit.

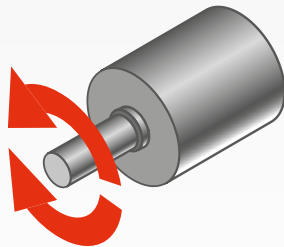

Easily reversed

Air motors work efficiently in either direction. They are easily reversed using a directional valve.

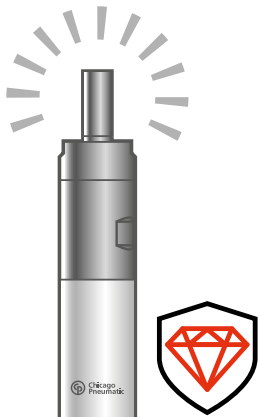

Rugged

Air motors are virtually unaffected by heat, vibration, corrosion or knocks and blows. Their performance in hostile environments cannot be matched by other types of motors.



Ideal in hazardous and hostile environments

Since air motors do not generate sparks they are ideal in areas where there are explosion and/or fire hazards. Moreover, their rugged design and construction make them ideal in salt-laden and other corrosive atmospheres.

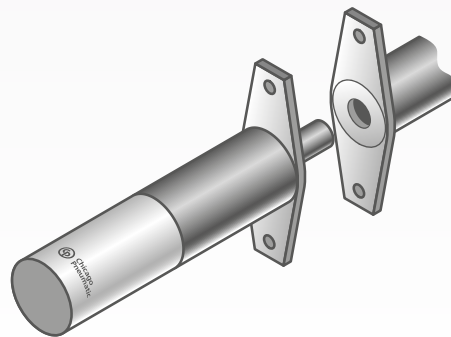

Simple to install

Air motors can work in any position. The motors and the required air lines are easy to install.

2. Design and working principle

There are several types of air motor. The most commonly used types are vane, piston and turbine motors. This technical guide deals with vane motors only. Vane motors are produced with power ratings up to approximately 5 kW.

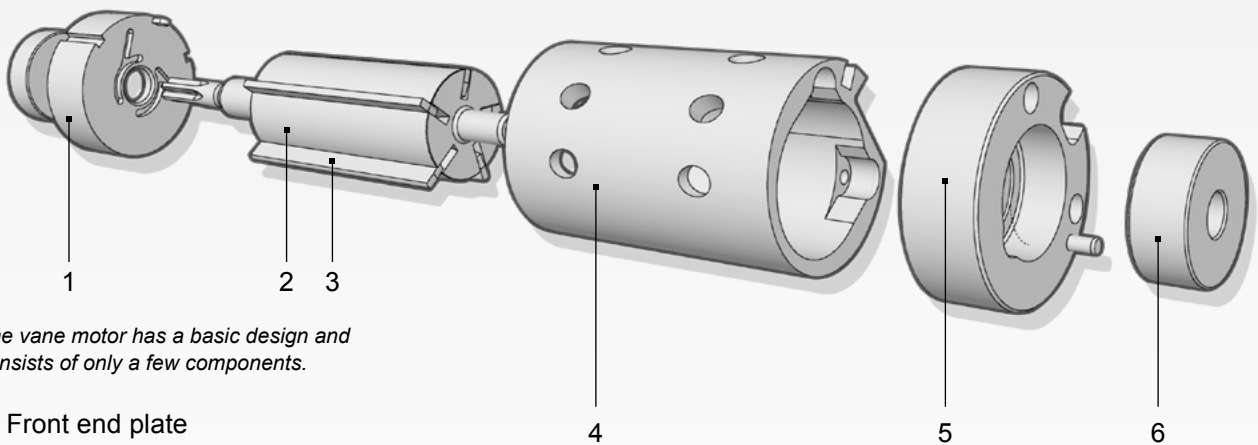

The vane motor has a basic design and consists of only a few components.

1. Front end plate
2. Rotor
3. Vane
4. Cylinder
5. Rear end plate
6. Bearing

Design

A slotted rotor rotates eccentrically in the chamber formed by the cylinder and cylinder end plates.

- Since the rotor is off-center and its diameter smaller than that of the cylinder, a crescent-shaped chamber is created.
- The rotor slots are provided with vanes that move freely to divide the chamber into separate working chambers of different sizes.
- As a result of the centrifugal force, which is often reinforced by the compressed air, the vanes are forced against the cylinder wall to seal the individual chambers.
- The actual efficiency of these seals is a function of what is called "internal leakage".

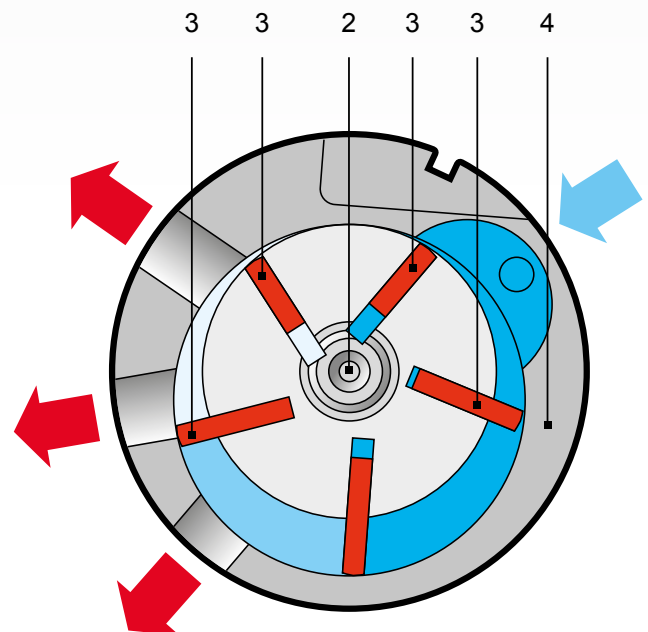

Working principle

- A. The air enters the inlet chamber "a". Vane 2 has just sealed off the chamber "b" between itself and vane 3. The pressure in chamber "b" is still the inlet pressure. This pressure acts on vane 3, moving it in a clockwise direction.
- B. The vanes have rotated further and the expansion process in chamber "b" has started. The pressure in it is thereby reduced but there is still a net force moving the rotor forward as the area of vane 3 is larger than the area of vane 2 in chamber "b". Furthermore the inlet pressure acts on vane 2 in the inlet chamber "a".
- C. The vanes have moved further. Chamber "b" is now being emptied through the outlet and there is no more contribution from this chamber. The force moving the rotor forward now comes from the force on vane 1 and vane 2.

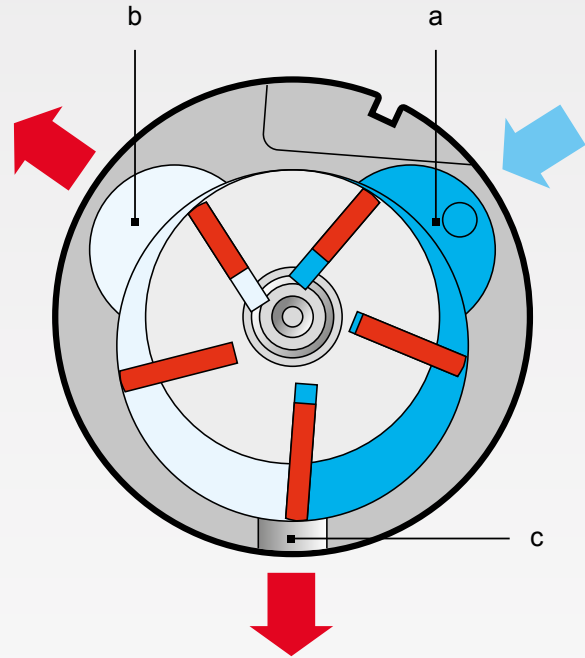

Thanks to this simple principle the energy of the compressed air is converted into rotational motion from chamber to chamber, and the motor turns.

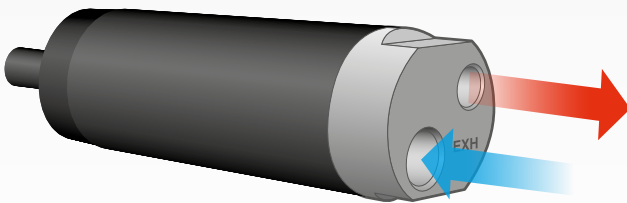

Working principle of an air motor.

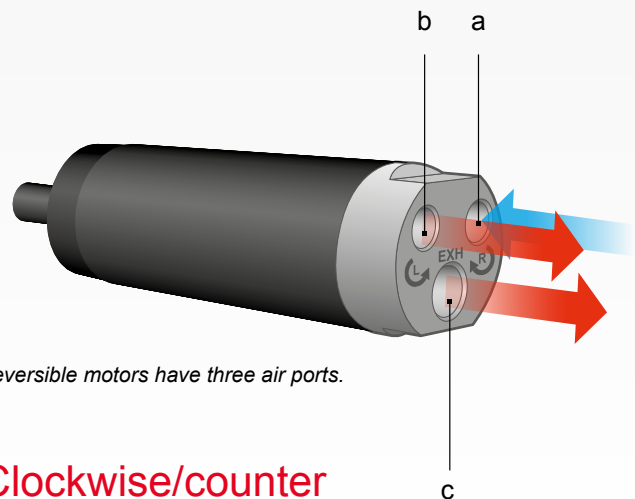

Reversible motors have three air ports.

Clockwise/counter clockwise/ reversible

The motor turns in a clockwise direction as seen from the rear end. Besides this type of vane motor there are also counter clockwise and reversible motors. Counter clockwise motors are designed the same way as the clockwise motors but the cross section is mirrored.

For a reversible motor port "a" is the inlet at clockwise rotation. Port "c" is the main outlet and port "b" is the secondary outlet. At counter clockwise rotation port "b" becomes the inlet and port "a" the secondary outlet. Port "c" remains the main outlet. The Chicago Pneumatic motors are designed as described above.

Rotor speed

During starting and at slow speeds, some of the compressed air flows under the vanes to press them against the cylinder wall and seal the various working chambers. When the rotor rotates, the vanes are forced against the wall of the cylinder by centrifugal force. At high speeds, however, the pressure exerted against the wall by the vanes must not be too great, or excessive wear will result.

The amount of wear is a function of the third power of the sliding speed between the tip of the vane and the cylinder wall and, in actual practice, this determines the maximum rotational speed.

In order to keep the centrifugal force down, high-speed motors, or rather their rotors, are long and slim and equipped with only three or four vanes.

Number of vanes

The number of vanes in the motor, which can range between 3 and 10, is an important design consideration. In general, the fewer the vanes, the lower the losses due to friction, but this also means that starting may be more difficult. If more vanes are provided, starting is easier and internal leakage lower, but there is more friction.

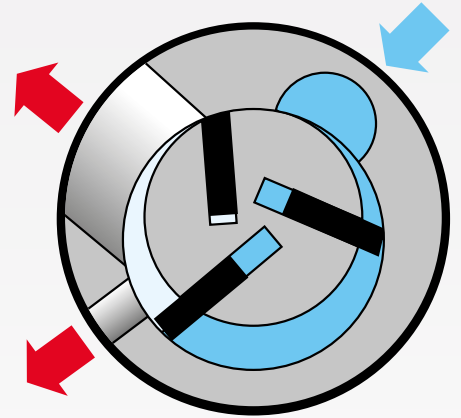

The number of vanes in the motor depends on which application the motor is designed for.

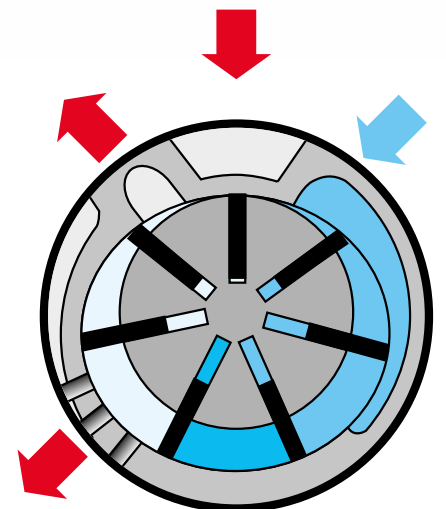
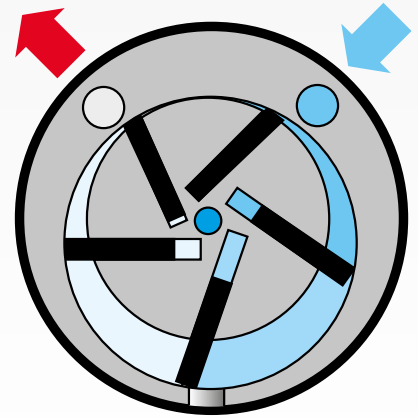

EXH

R

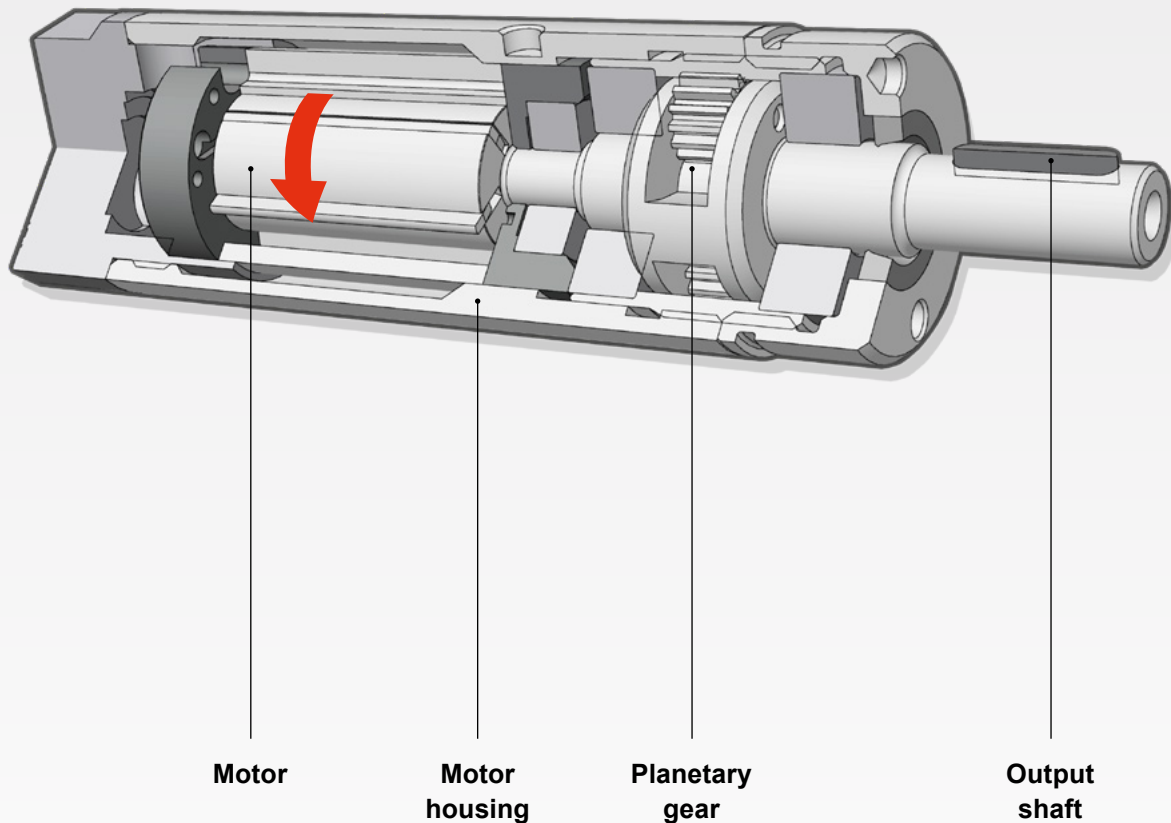

Gears

The rotor of a vane motor turns at quite high speed.

The free speed of a motor is typically around 20 000 rpm. For most applications these speeds are too high and the rotor torque is also rather small. To convert a high speed and low torque to lower speed and higher torque, gears are used.

Chicago Pneumatic's vane motors are supplied with different types of gears: planetary gears and helical gears (see Appendix).

Lubrication free motors

The traditional vane motors are lubricated by the compressed air to which a small amount of oil is added. Lubrication free motors do not need any oil added to the air. These motors are equipped with vanes made of a special low friction material and have permanently lubricated bearings. When long service life is the first priority lubricated motors should be chosen because their vanes last longer.

Motors with brakes

The brake is located between the motor and the gear. It is a disc brake that is spring activated when the motor is not running. When the motor is started the brake is released by a built-in pneumatic piston.

The brake is used when it is important that the output shaft must not turn when the motor isn't running and a torque is applied on the shaft.

3. The performance of an air motor

The performance of an air motor is dependent on the inlet pressure. At a constant inlet pressure, air motors exhibit the characteristic linear output torque/speed relationship. However, by simply regulating the air supply, using the techniques of throttling or pressure regulation, the output of an air motor can easily be modified.

One of the features of air motors is that they can operate over the complete torque curve from free speed to standstill without any harm to the motor. The free speed or idling speed is defined as the operating speed where there is no load on the Speed [rpm] output shaft.

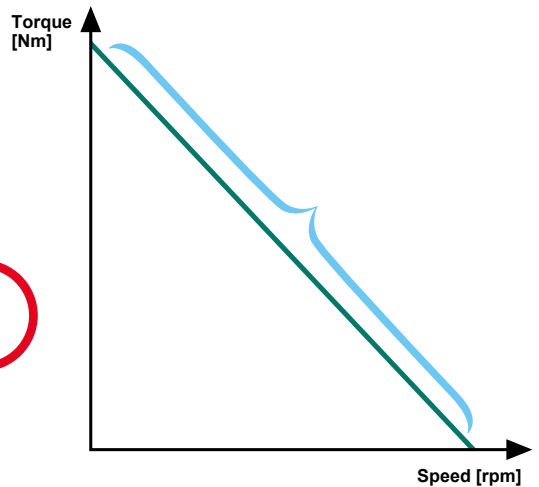

Free Speed = speed at which the outgoing shaft rotates when no load is applied.

The motor can operate over the complete torque curve.

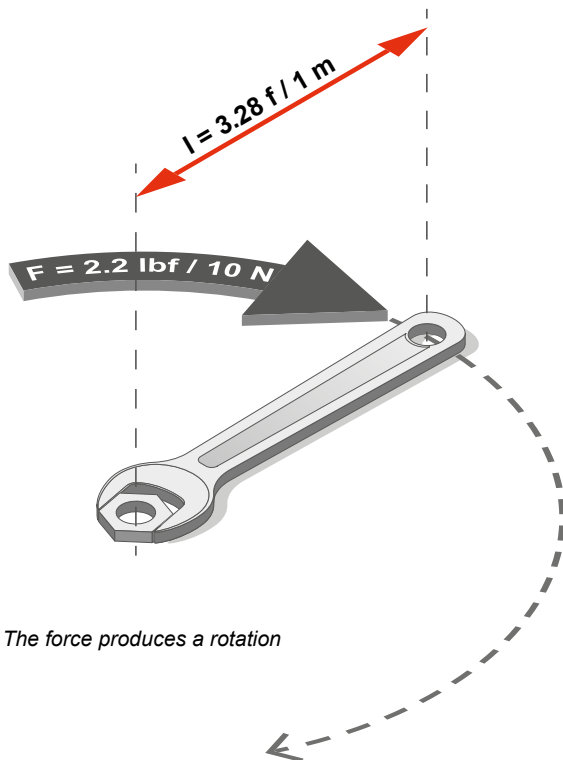

The force produces a rotation

Torque is the rotating force that is calculated as force (F) times the length (l) of the lever.

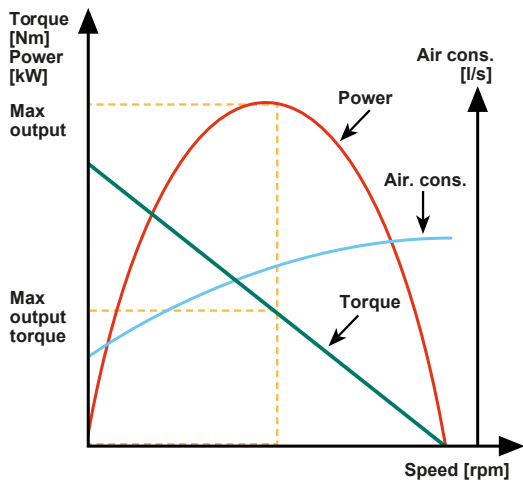

The performance curve for an air motor operating at a constant air pressure.

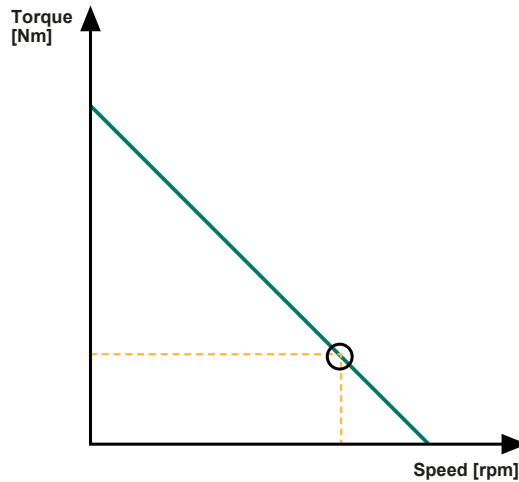

The working point for an air motor.

The power curve

The power that an air motor produces is simply the product of torque and speed. Air motors produce a characteristic power curve, with maximum power occurring at around 50% of the free speed. The torque produced at this point is often referred to as “torque at the maximum output.”



Output formula

$$P = (\pi \times M \times n) / 30$$

$$M = (30 \times P) / (\pi \times n)$$

$$n = (30 \times P) / (\pi \times M)$$

P = power [kW]

M = torque [Nm]

n = speed [rpm]

The working point

When selecting an air motor for an application the first step is to establish the “working point”. This is the combination of the desired operating speed for the motor and the torque required at that point.



The point at the torque/speed curve where the motor actually operates is called the working point.

Air consumption

The air consumption for an air motor increases with the motor speed and thus is highest at free speed. Even at standstill condition (with full pressure applied) the motor consumes air. This depends on the internal leakage in the motor.



Air consumption is measured in l/s.

This is however not the actual volume that the compressed air occupies in the motor but it is measured as the volume it would occupy if allowed to expand to atmospheric pressure. This is a standard used for all pneumatic equipment.

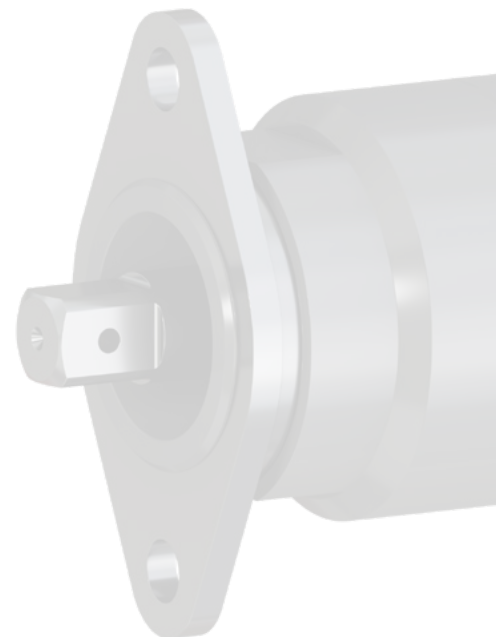

Starting torque

Starting torque is the maximum torque that can be produced by a motor in order to start rotational movement of the load.

It should be noted that all vane air motors produce a variable starting torque due to the position of the vanes in the motor.

The lowest starting torque value is called the minimum starting torque and can be considered as a guaranteed value at start up. The variation differs between motor types and must be checked on an individual basis.

It is notable that the torque variation is greater for reversible motors than for non-reversible motors and therefore the minimum starting torque is smaller for these motors.

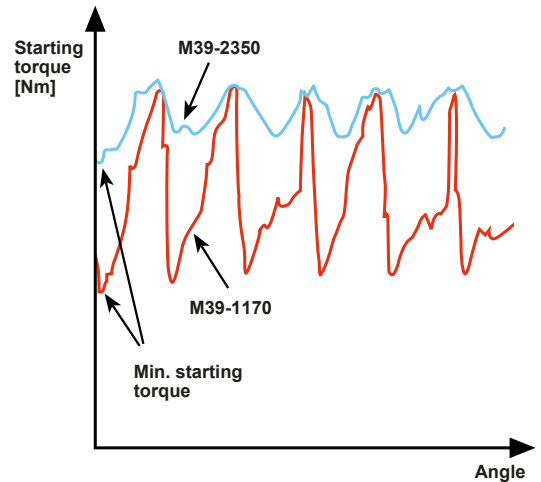

At start up the torque varies with the vane position.



An other definition is the starting torque is the torque that a motor gives with blocked shaft when you feed full air pressure into it.

Stall torque

The stall torque is the torque that a motor gives just when it stops after being braked to a stop from a running condition. In other words, when the load exceeds the maximum possible torque of the motor, it stalls.

An easy way to approximate the stall torque is to multiply the maximum power torque by two i.e., a maximum power torque of 10 Nm equals a stall torque of approximately 20 Nm.

The stall torque varies depending on how fast the motor is braked down to stall. A fast braking down results in higher stall torque than a slow braking down. This depends on the fact that the mass (moment of inertia) from the rotor increases the torque.

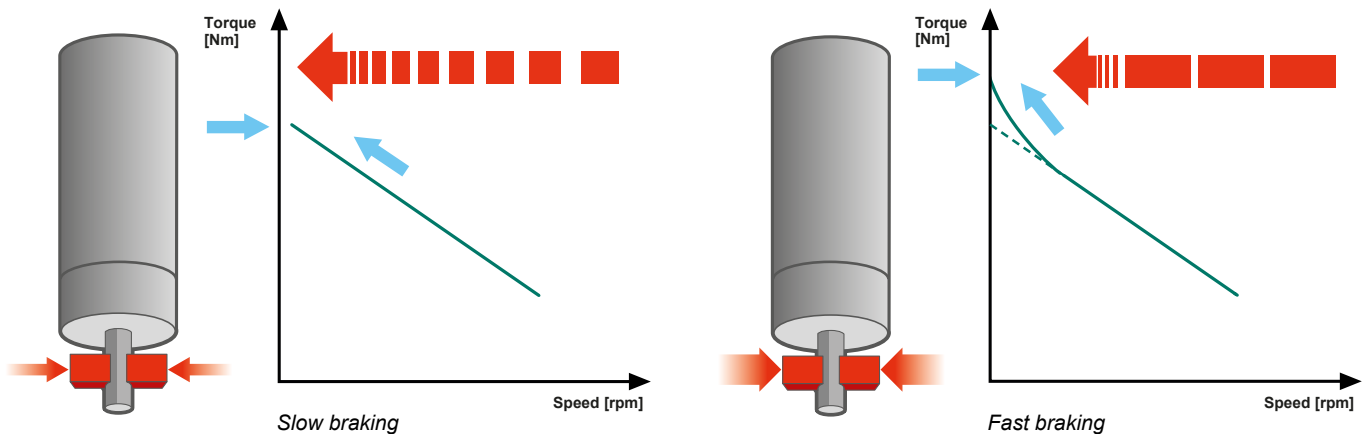

4. The use of gear units

Air motors operate at high speeds and although they can be controlled over a wide speed range, the output characteristics are not always suitable for the application. To achieve the required output an appropriate gear unit can be selected.

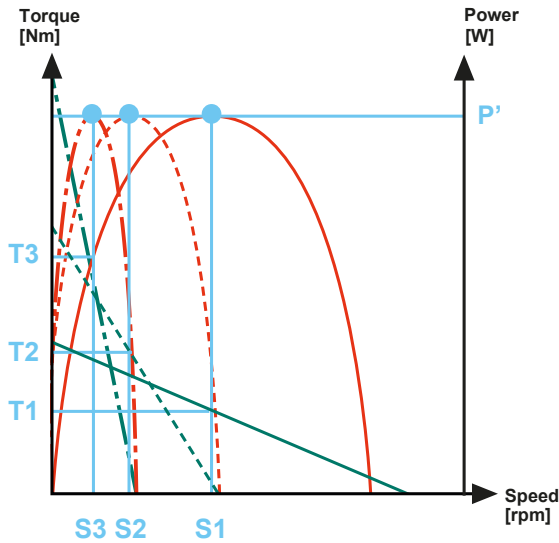

Changing reduction with gear box does not change the power but decrease the motor speed and increase torque proportionally.

Reduction ratio 1:1
Reduction ratio 1:2
Reduction ratio 1:3

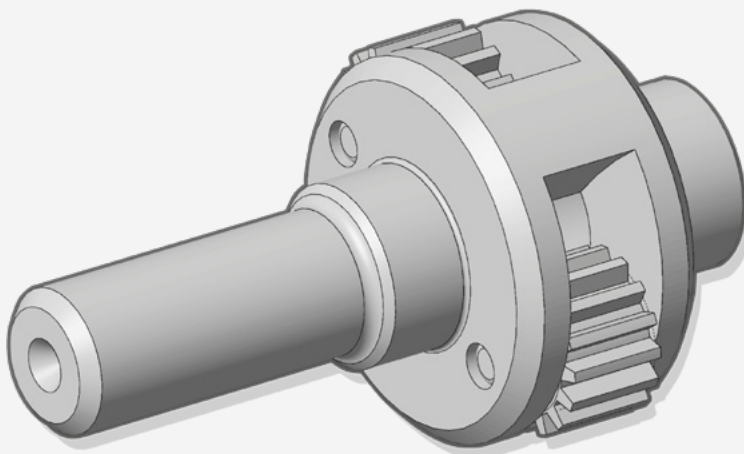

The planetary and helical gear units used by Chicago Pneumatic have a high level of efficiency that can be assumed to be 100%. Evidently, while the torque/speed relationship undergoes a considerable change, the power output remains virtually unchanged.

The torque is increased and the speed is reduced proportional to the gear ratio.

5. Shaft loading

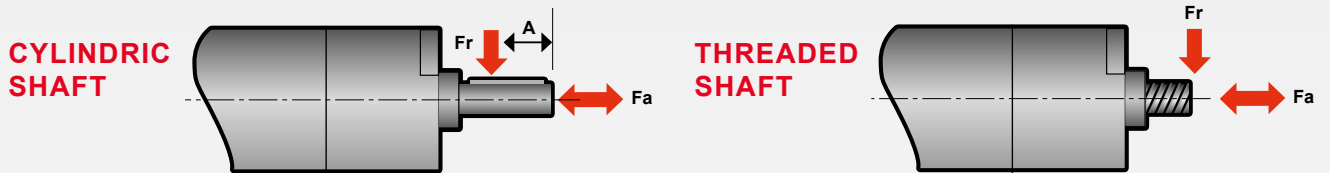

Shaft loading on an air motor affects bearing life. The design of the motor is long and slim. This gives a number of advantages, such as high power-to-volume ratio, low air consumption and long vane life. All motors utilize five vanes, which are supplied with vane air, to ensure excellent starting and low speed performance. Multi-step planetary gears are used to meet the torque and speed requirements.

The maximum allowable loads on a given motor's output shaft are illustrated table hereunder. The relevant load curve code for a motor is stated in the data tables for each specific motor designation, under the "Shaft load code" column. These values have been calculated for shaft and bearing working lives of 10 million turns. To achieve a working life of 100 million turns, the loading factor must be halved.

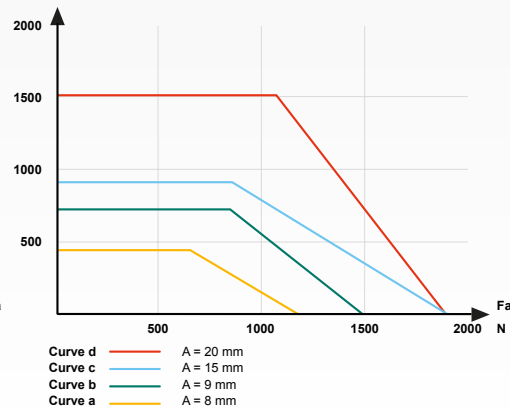
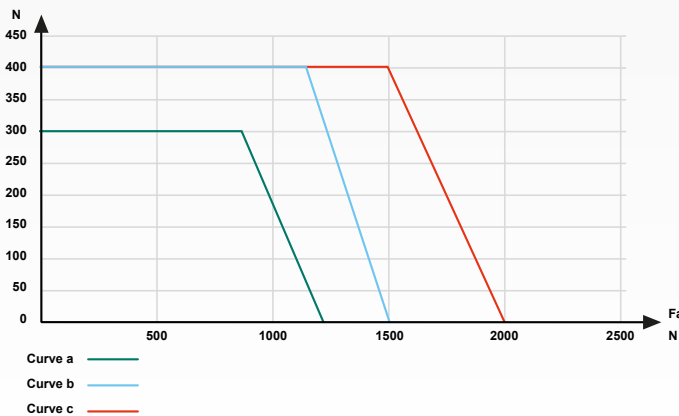

Conversion factor

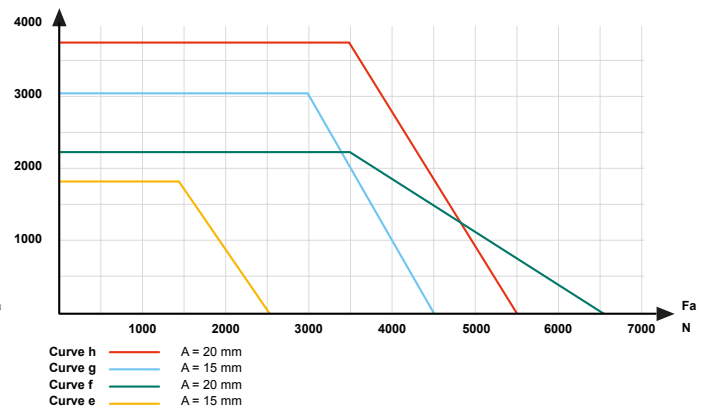
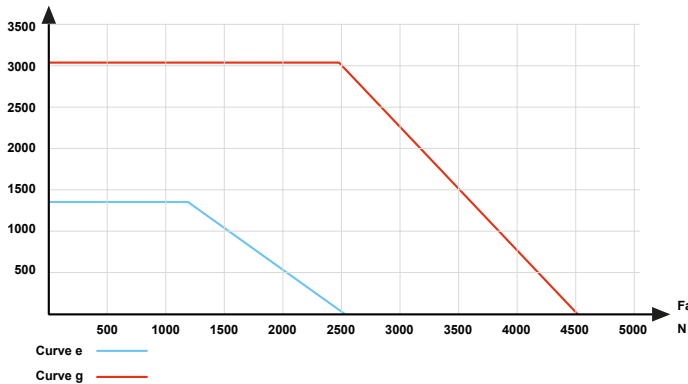

6. Methods of modifying motor performance

Two methods can be used to modify the performance of an air motor. Throttling and/or pressure regulation. The conditions for the application decide which method is the preferred one.

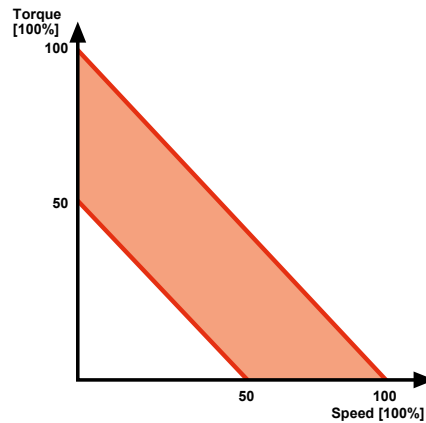
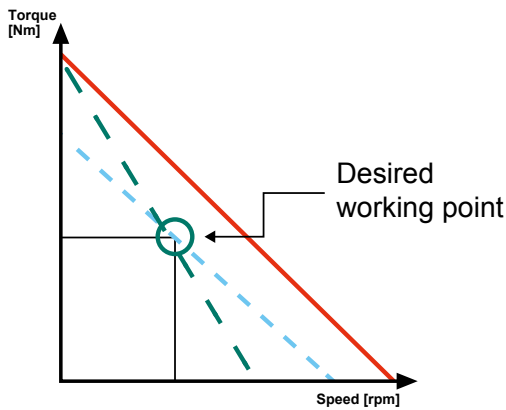

When selecting an air motor for a certain application, the first step is to establish what is called the “working point”. This is the point described by the desired operating speed for the motor and the torque required at that speed.

The free speed and torque can be regulated down to 50% for Chicago Pneumatic air motor. The air motor can operate anywhere within the shaded area.

Throttling

A throttle is usually fitted into the motor’s inlet, although it can also be fitted into the exhaust. The benefit of throttling the inlet is that air consumption is reduced, whereas throttling the exhaust air maintains a slightly higher starting torque. When it is desirable to maintain a high starting torque but reduce running speed, throttling is the best method of modifying the motor’s output.

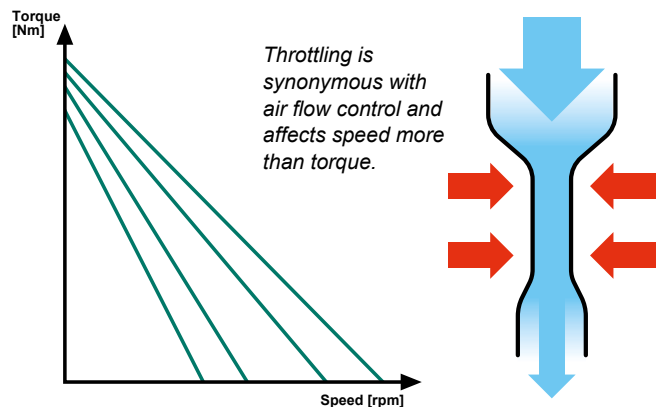

| Air supply reduction | Air exhaust reduction |
|----------------------------------|------------------------------|
| Reduces Speed | Reduces Speed |
| Decrease air consumption | Keeps a good starting torque |
| Reduces starting torque | Keeps stability |
| May impact functioning stability | |

Pressure regulation

When using a pressure regulator, it is always fitted into the inlet of the motor. The use of pressure regulation is ideal when control of the stall torque is required, and a high starting torque is unimportant.

Motor performance with other air pressures

All performance graphs of Chicago Pneumatic air motors are given for an inlet pressure of 6.3 bar. For other air pressures the performance curves must be recalculated. To calculate performance data the motor data at 6.3 bar has to be multiplied by the correction factor shown in table 1.

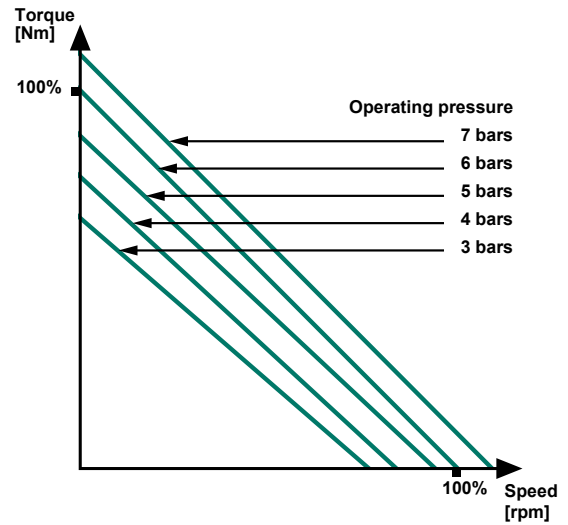

CORRECTION FACTORS

| Air pressure | | Output | Speed | Torque | Air consumption |
|--------------|-------|--------|-------|--------|-----------------|
| (Bar) | (Psi) | | | | |
| 7 | 101 | 1,13 | 1,01 | 1,09 | 1,11 |
| 6 | 87 | 0,94 | 0,99 | 0,95 | 0,96 |
| 5 | 73 | 0,71 | 0,93 | 0,79 | 0,77 |
| 4 | 58 | 0,51 | 0,85 | 0,63 | 0,61 |
| 3 | 44 | 0,33 | 0,75 | 0,48 | 0,44 |

Table 1

7. Using catalogue performance data

The performance data stated in Chicago Pneumatic air motor online catalogue is valid for an air supply pressure of 6.3 bar (91 psi), gauge. The data in the online catalogue is available both in tables and diagrams.

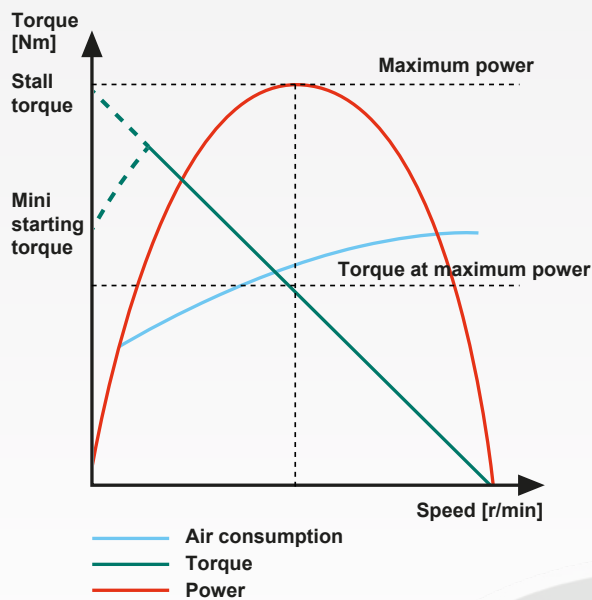

The output of an air motor is most clearly seen from its performance diagram. For each motor/gear unit the power, torque and air consumption are shown as a function of speed.

- Maximum power, kW and hp
- Speed at point of maximum power, rpm
- Torque at maximum power, Nm
- Free speed, rpm
- Air consumption, l/s
- Stall torque, Nm
- Starting torque, Nm



8. How to choose the right motor

When selecting the right motor for any given application, it is advisable to consider what needs must be satisfied. A good way to do this is by using the step-by-step process described below.

- Low starting torque
- Insatiable speed
- Low air consumption
- High load on gears
- Low vane wear

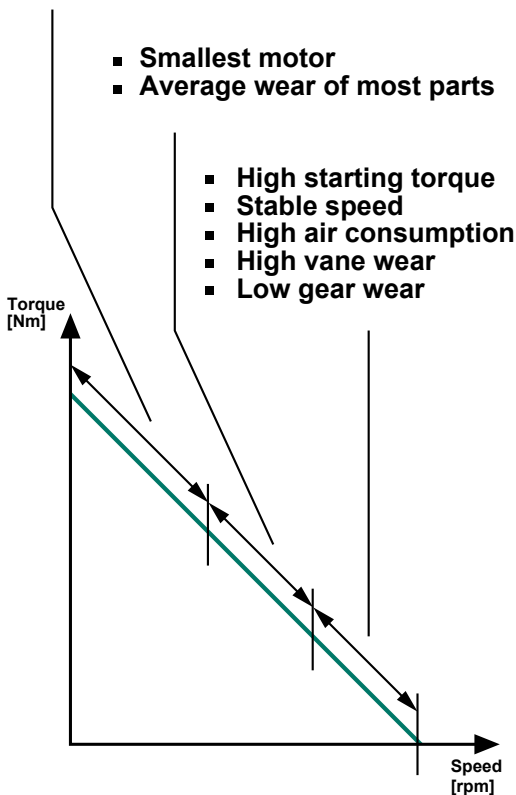

Different working point areas

General rules for selecting air motors

The wide operating range of an air motor makes it probable that a number of different motors could run at the same working point. Your choice of motor will be influenced by where you find the working point on the torque-speed curve.

Because it is most efficient to run the motor at the speed of maximum power, selecting the one that produces maximum power as close to the working point as possible will give you the smallest possible alternative. This motor will also give the lowest air consumption for a given power output.

If stable speed of the air motor is important you should avoid working with speeds below the point of maximum power. This assures that there is some "reserve power" in the case of load increase. It is also a good idea to work closer to the idling speed when there is uncertainty about the torque demand.

Low speed/high torque makes the load on the gears high. High speeds affect the lifetime of the vanes.

If a very long lifetime is demanded, a large motor that is restricted or run at a low pressure should be chosen.

EXAMPLE 1

A non-reversible motor is required to run at 300 rpm and produce a torque of 10 Nm. Select the most suitable motor for this application.

1. In the example the required power is $P = \frac{\pi \times \text{Torque} \times \text{Speed}}{30} = \frac{3,14 \times 10 \times 300}{30} = 314 \text{ W (0.314 kW)}$
2. Select a motor type with the right power output from the air motor online catalogue. In this case we choose the M39 (0.39 kW)
3. Look at the performance curves for each motor variant and select the one that has its maximum power nearest to the working point.
4. The two motors that best match the demand are M39-650 and M39-520. The first choice should be M39-520 as we then work with a speed above the maximum power point and thereby give a higher starting torque and more stable speed.

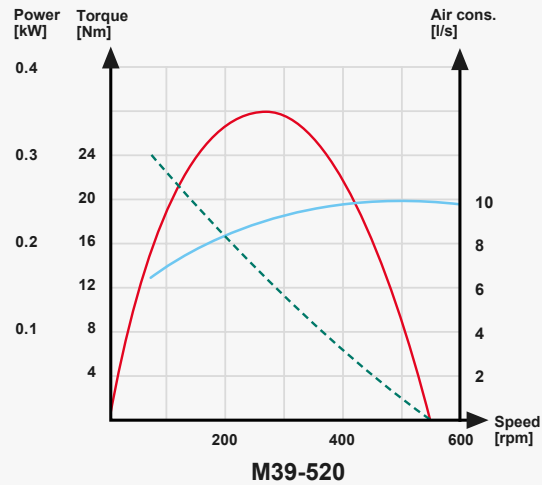
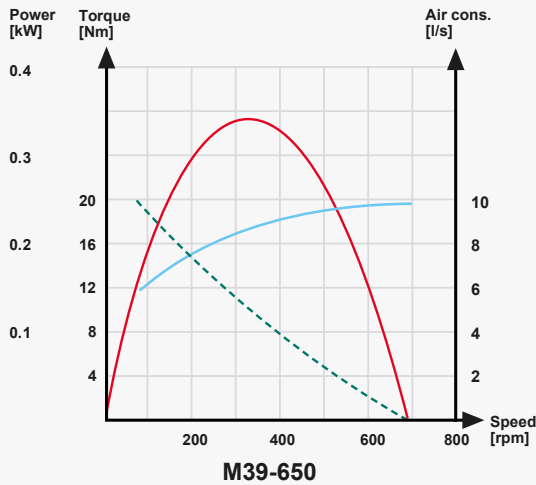

5. To validate the choice, the working point should be plotted on the performance chart provided on Chicago Pneumatic online catalogue

- **1** select the air motor speed characteristics line
- **2** & **3** report the torque and speed value on the chart
- **4** The intersection of both curves should be located below the Torque/Speed curve

When the working point is plotted, it is often noted that the motor has to be slightly adjusted for the working point to coincide with the performance graph. This can be done in two ways, adjusting air flows or air pressure.

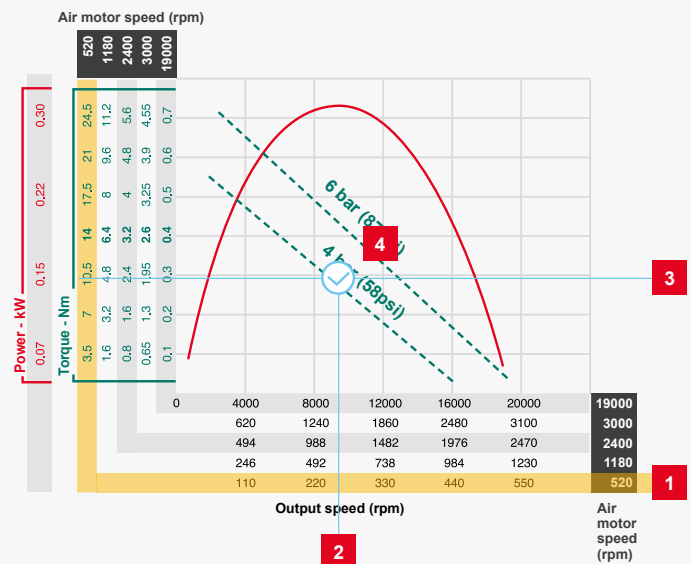

Different operating parameters

Normally operating parameters are adequately described by giving the required torque and corresponding speed. Six common additional requirements frequently occur:

- Starting torque
- Stall torque
- Free speed
- Air consumption
- Service life
- Shaft loading
- Efficiency
- Power reserve

The motor must produce a certain torque at start up

Many applications demand that a motor produce at least a threshold torque at start up. This can be the case when a motor is to move a load. The minimum starting torque for a given motor has to be looked up in the tabular data.



Chicago Pneumatic

EXAMPLE 2

An air motor is to be used to operate a trolley. The working point for the motor is 5 Nm at 300 rpm. Since starting characteristics are essential the motor also has to have a starting torque of 20 Nm.

The power requirement will be:

$$P = \frac{\pi \times \text{Torque} \times \text{Speed}}{30} = \frac{3,14 \times 5 \times 300}{30} = 157 \text{ W (0.157 kW)}$$

The correct motor size for this application is the M25 (0.25 kW).

The performance graphs show that the M25-1040 meets the requirements for the working point. However, the air motor can only guarantee a starting torque at 10Nm. The demand is that the minimum starting torque is to be 20 Nm, we must choose a motor with another gear ratio. As we need a higher starting torque we consequently need a motor with a higher gear ratio.

The M25-480 has a minimum starting torque of 22 Nm and is a good choice for this application.

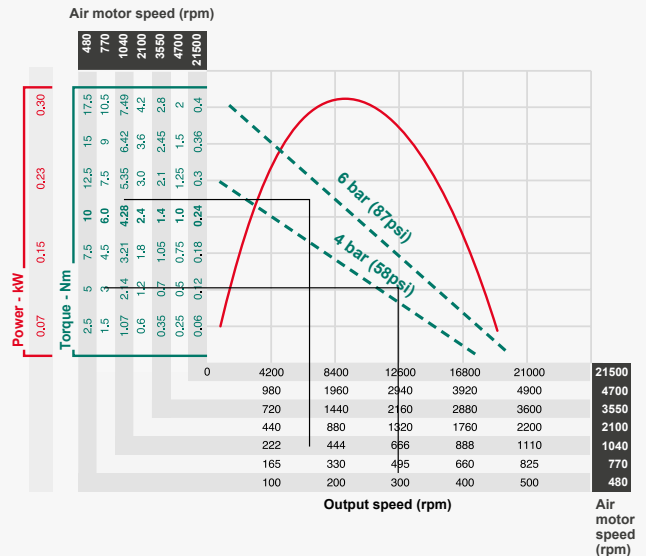

The motor must reach a specified **stall torque** and also a specified **free speed**

Two common applications for air motors are strapping tools for packaging and tools for assembling threaded joints. Both these applications place demands on free speed and stall torque. The free speed defines how fast the process will be. This is because much of the time the motor is working at low torque, such as when taking up the slack during strapping and the rundown during screw fastening. The stall torque defines the tension in the strap and the installed torque of the threaded joint.

EXAMPLE 3

We assume that we are looking for a nutrunner motor that can tighten a nut to 25 Nm and can run down the free spinning nut at a speed of 500 rpm. In this case the motor must not be reversible.

We also know that the free speed is twice the maximum power speed. That means that we should look for motors with at least 12.5 Nm maximum power torque and 250 rpm maximum power speed.

This requires a motor with

$$P = \frac{\pi \times \text{Torque} \times \text{Speed}}{30} = \frac{3,14 \times 12,5 \times 250}{30} = 327\text{W}$$

which guides us to start looking among the non-reversible M39 motors. We find a motor that looks suitable, M39-520. It has maximum power torque 14 Nm (stall torque 28 Nm) and free speed 550 rpm at 6.3 bar. If we must have exactly 25 Nm stall torque we must adjust the torque down a little. Reducing the pressure slightly with a pressure regulator should do this.

Pressure regulation will also take down the speed a little but less than if you restrict the airflow and we will still be above 500 rpm.

M39-520 will be a good choice for the nutrunner application.

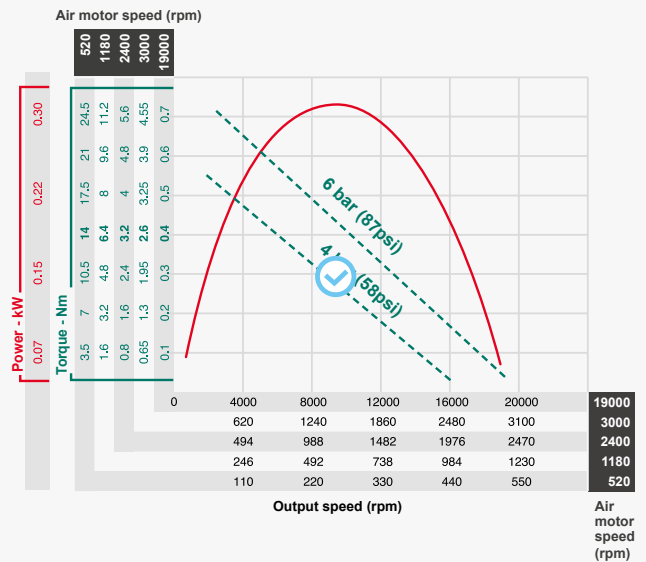

Service life

The service life of a motor is highly dependent on the working conditions.

If the working cycle is a mix of free running, running at maximum power and braking down to stall, the service life of lubricated vanes for Chicago Pneumatic motors is typically 2 000 hours and lubrication free vanes 1 000 hours.

To determine the service life more exactly we recommend an initial inspection based on the above recommended time intervals. The Product Instructions supplied with the motor specify the maximum allowed vane wear for each motor type and size. A change of vanes is recommended before the wear exceeds these values.

EXAMPLE 4

The application is running at torque 2.5 Nm and speed 600 rpm. It runs for 8 hours per day, which puts high demands on service life and reversible.

The working point tells us that the power must be at least $3.14 \times 2.5 \times 600/30 = 157 \text{ W}$. One motor that satisfies this working point is MR39-800.

When we have 8 hours running per day we should oversize the motor and adjust down the performance by pressure regulation or flow restriction.

MR39-1700 is one alternative. We find that the speed at the working point is very low compared with the free speed, this indicates long service life of the vanes. On the other hand the torque is closer to the maximum power torque which can limit the lifetime of the gears. To reach the working point in this case you can either reduce the air pressure or restrict the airflow.

An oversized motor will give long service life.

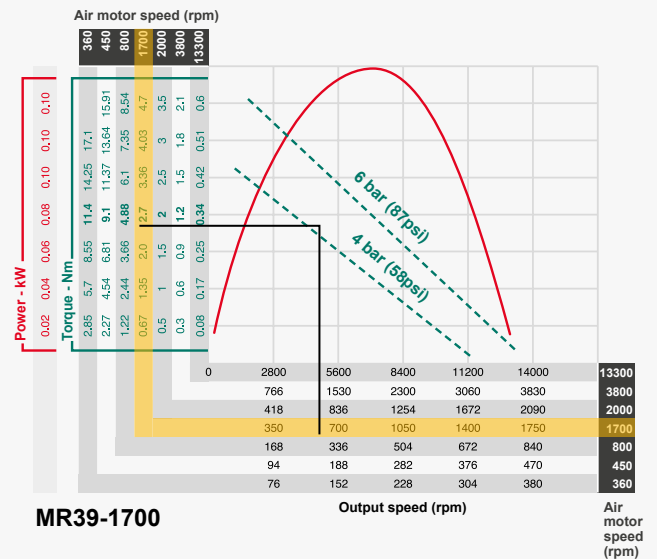
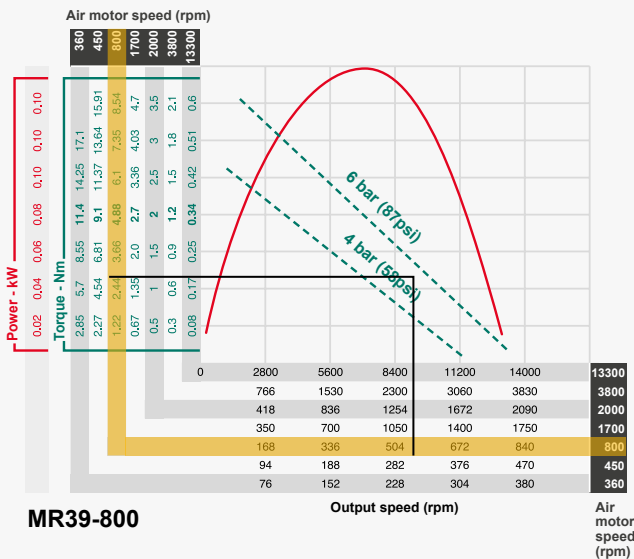

Air consumption

When low air consumption is a major concern you should as priority try to find the smallest possible motor. If you have decided on a motor size and have different options within this size you should know the closer the motor works to its free speed, the higher the air consumption will be.

If you choose to adjust down the performance of a motor, you will get the lowest air consumption by airflow restriction (on the motor inlet) rather than pressure regulation.

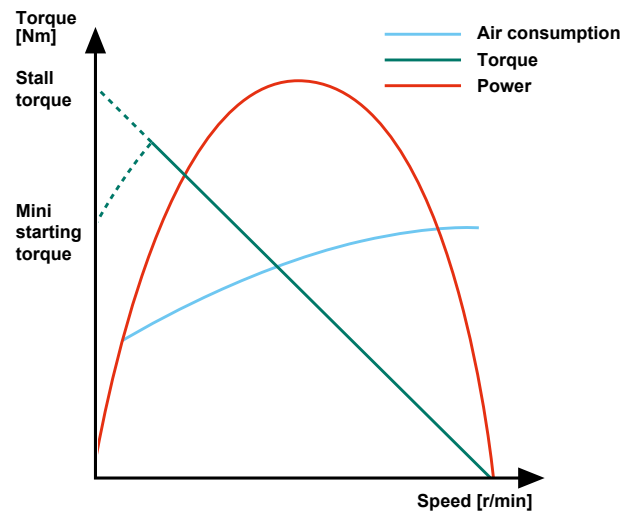

Shaft loading

The maximum allowable shaft load is specified in the chapter 5. In the data tables shaft loading codes are listed. These codes point to curves where the allowed combinations of radial and axial shaft load are defined. It is a good idea to check that the application will not give shaft loads above what we allow. In some rare cases you might have to choose an oversized motor just to be able to manage the shaft loads.

Efficiency

The customer is willing to get the motor working at 2.7 Nm with the more power but to save space and money. Speed is not an issue. We already know that the MR39 air motors have the power he required. The best option is to optimize ratio power / air consumption.

Looking at 2 motors with same power but different speed like MR39-1700 (2) and MR39-2000 (1), for the same output torque. P2 is at the maximum power and higher than P1: **Air motor MR39-1700 is the more efficient.**

For MR39-1700, the torque 2,7 Nm is reached at the maximum power (P2) at 850 rpm (S2)

For MR39-2000, the torque 2,7 Nm is reached at a lower power (P1) at 500 rpm (S1)

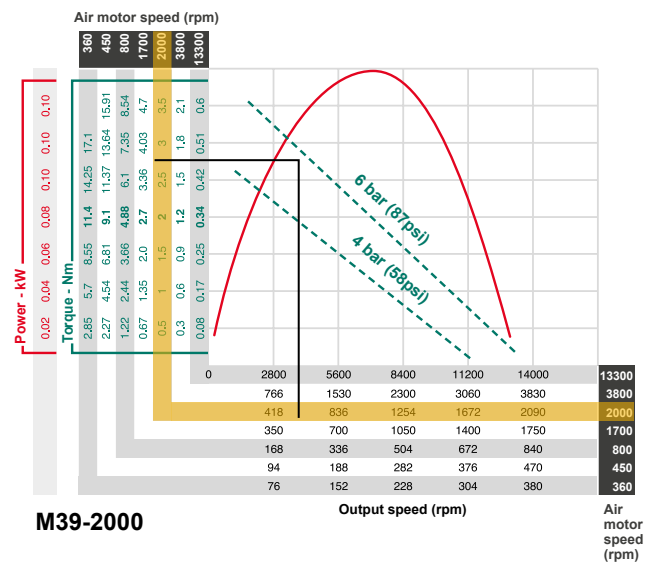
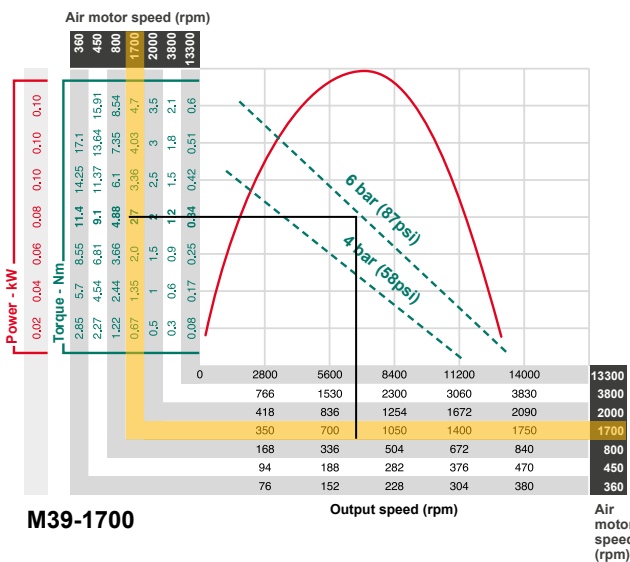
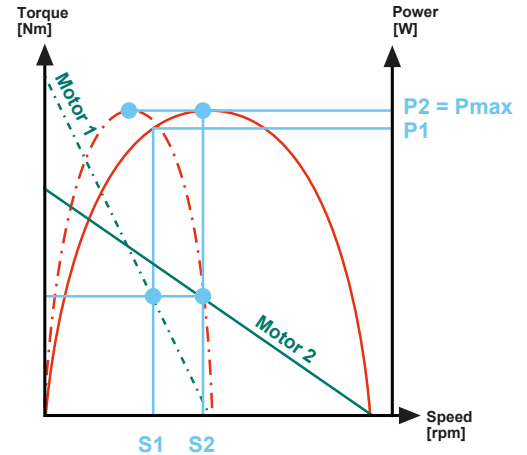

Power reserve

Looking for a power reserve means that the air motor has to be able to face a load increase without too much speed reduction and keep the power if load fluctuates.

For the initial torque T, P2 > P1 and motor 2 seems to be the best choice. When the torque increases from T to T':

- Motor 1, the speed reduces from S1 to S'1 and the power slightly increases from P1 to P'1
- Motor 2, the speed reduces from S2 to S'2 and the power decreases a lot from P2 to P'2

The speed fall is more important for the motor 2 than the motor 1: S2-S'2 > S1-S'1

Motor 1 has the best power reserve for the application.

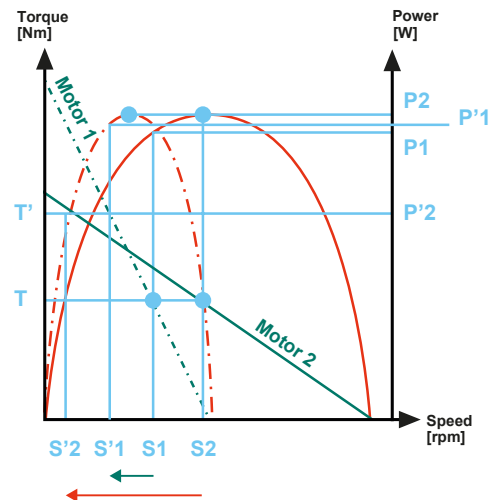

9. Silencing

The noise generated by an air motor is mainly caused by the exhaust air exiting the motor. The noise level increases with speed and is greatest at free speed.

All Chicago Pneumatic motors are supplied with a threaded exhaust port permitting a screw-in silencer to be fitted to reduce noise level. By fitting a hose between the exhaust port and the silencer the noise level can be reduced even further. The effect of employing the various silencing techniques is indicated in table 2. Note that a silencer may cause power losses if incorrectly sized.

| 0.36 kW motor No-load speed Anechoic room Interval of 1 minute | Measure | Noise Level dB (A) |
|---|---------------------------|-----------------------|
|  | <i>None</i> | 94 |
|  | <i>Silencer only</i> | 77 |
|  | <i>Hose only</i> | 84 |
|  | <i>Hose with silencer</i> | 75 |

Table 2

Different noise reduction possibilities and the effects thereof: the noise values are fictitious and only relevant in relation to one another

10. Installing your air motor

An air motor needs a certain amount of air and a certain pressure to function. Supply and exhaust hoses must therefore be properly dimensioned.

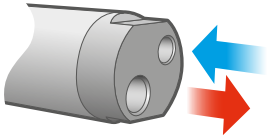
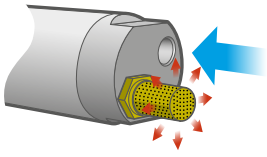
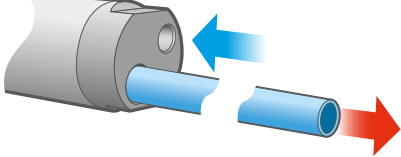
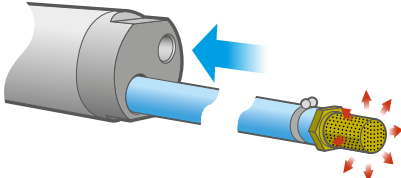
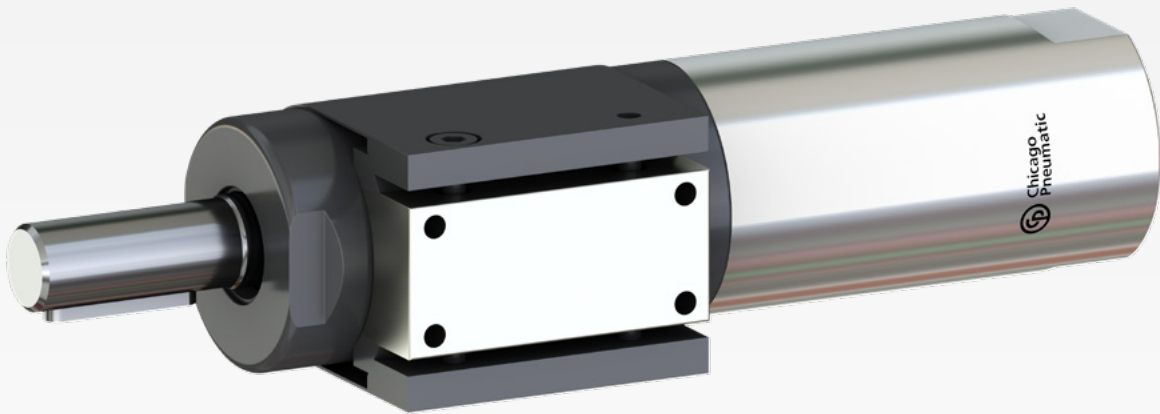

Air lines

Using air lines that are too long or under-dimensioned will result in pressure drops. As stated earlier in this guide, this means power losses. The exhaust line must have a larger dimension than the supply line. This is because the exhaust air occupies a larger volume than the supply air. For an inlet pressure of 6.3 bar (= 7.3 bar absolute) and an outlet pressure at atmospheric level (= 1 bar absolute) the volume increase is a factor of 7.3. In practice this means that if the same dimensions are used for inlet and outlet lines a back pressure is built up and the motor loses its efficiency.

| Specifications | Values | CHICAGO PNEUMATIC | | | | |
|------------------------|--------|-------------------|-----------|-----------|-----------|------|
| | | M16 | M25-M2501 | M39-M3901 | M84-M8401 | M180 |
| Model name | | M16 | M25-M2501 | M39-M3901 | M84-M8401 | M180 |
| Inlet connection | BSP | 1/8" | 1/8" | 1/4" | 1/4" | 3/8" |
| Inlet hose* | [mm] | 8 | 8 | 10 | 10 | 13 |
| Inlet nipple diameter | [mm] | 5 | 5 | 8 | 8 | 9,3 |
| Outlet connection | BSP | 1/8" | 1/8" | 1/4" | 1/4" | 3/8" |
| Outlet hose* | [mm] | 8 | 8 | 10 | 10 | 19 |
| Outlet nipple diameter | [mm] | 5 | 5 | 8 | 8 | 17 |

**recommended minimum inner diameter (for reversible motors, the same size should be used on both in/outlet)*

Information on hose dimensions are valid for hose lengths up to 3m. If lengths above that are used, choose a hose one size larger

Connection

Non-reversible motor

When the compressed air supply is connected to the inlet, the direction of rotation will be as shown in Figure. If the exhaust air is to be piped away, a hose should be connected to the exhaust outlet (EXH).

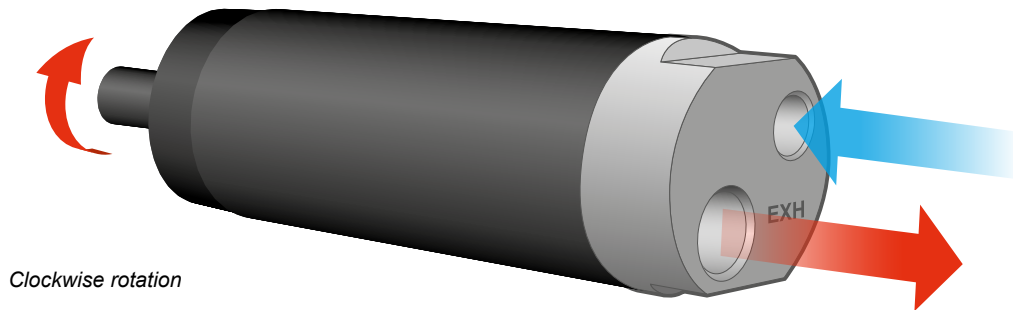

Reversible motor

The compressed air supply should be connected to the inlet that gives the desired direction of rotation, Figure hereunder. The inlet not in use functions as an additional outlet: it must not be plugged.

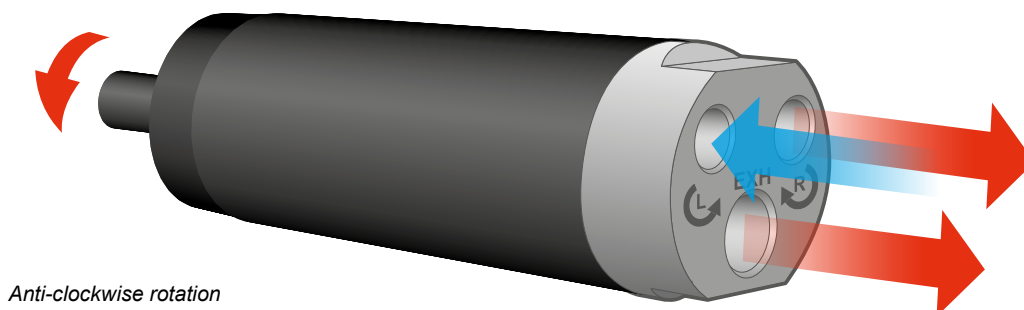
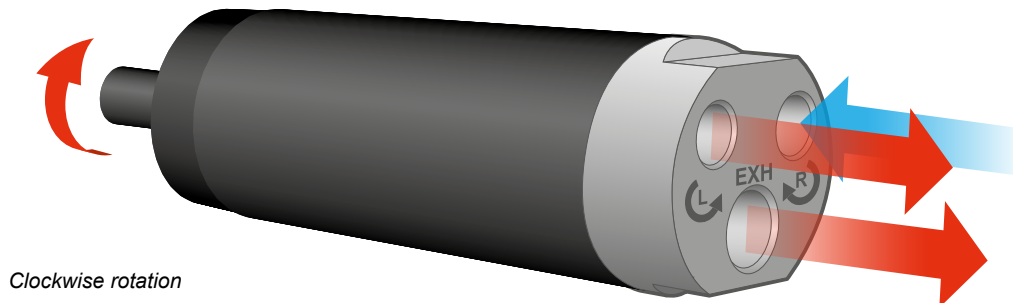

Air preparation

For optimum performance and maximum machine life we recommend the use of compressed air with a maximum dew point of +10°C. We also recommend the installation of a refrigeration-type air dryer.

To ensure reliable service an air filter and lubricator (not mandatory if the motor is lubrication free) should be fitted into the inlet airline – within 5 meters from the motor. It is recommended that a pressure regulator is also incorporated into the air preparation package. This has the function of maintaining the desired working pressure, and can be used to modify the output exactly to meet the needs of the application.

The filter shall remove solid particles larger than 15 microns and also remove more than 90 % of liquid water.

Remember: when selecting an air preparation package, ensure all components have a flow.

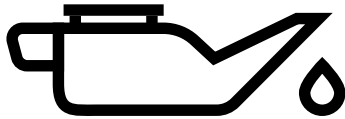

Lubrication

To achieve optimum service life and performance an air motor should be supplied with 50 mm³ of oil for each cubic meter (1 000 liters) of air consumed. Insufficient lubrication will result in accelerated vane wear and a reduction in performance.

The following example shows how to calculate the lubrication required by a motor running at a known output.

The lubricator oil selected should have a viscosity of between 50 and 300 × 10⁶ m²/s at the working temperature. The table below shows how reduced lubrication can affect service life and power for a lubricated vane motor.

EXAMPLE

A non-reversible M39 motor running at maximum output consumes 8.1 l/s. of air.

In one minute it consumes 498 (8.3 × 60) liters of air, therefore the lubrication required is: 498/1000 × 50 = 25 mm³/min.

If an oil-fog lubricator is used it should be set to deliver 2 drops of oil per minute (1 drop = 15 mm³).

| Lubricant Quantity | Service life | Output power |
|------------------------------------|--------------|--------------|
| mm ³ oil m ³ | hours | % |
| 50 | 1000 – 3000 | 100 |
| 10 | 500 – 100 | 100 |
| 1 | 200 – 500 | 90 |
| 0.1 | 100 – 300 | 80 |
| 0 | 10 – 30 | 30 |

1 drop of oil is approx. 15 mm³

Lubrication free vane motors

Chicago Pneumatic air motors are available with lubrication free vanes as standard. If running a motor with 100% dry air and no lubrication, performance can be reduced by 5-15% at max. output depending on model. Free speed will be more affected, reduced by 10-30%. To optimize the service intervals for a lubrication free vane motor, use lubricated air if the application allows it.

Directional control valves

These valves are used to start or stop a motor, or to change its direction of rotation. It is most usual to use what is termed as a 5/3 valve to control a reversible motor, and a 3/2 valve to control a non-reversible motor. The valve designations refer to the number of connection ports and the number of operating positions the valve provides. For a 5/3 valve this is 5-connection ports and 3 positions.

When selecting any control valve it is important to ensure that it has a flow capacity that is sufficient to supply the requirements of the motor.

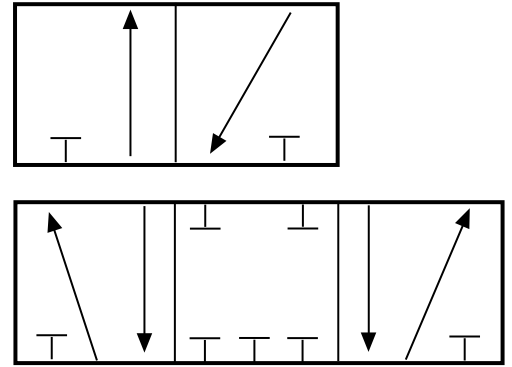

The symbols used to represent these valves on an installation diagram.

Installation examples

Typical installation diagrams for air motors, together with their associated control valves, filters, regulators lubricators and silencers.

- A = Filter
- B = Pressure regulator
- C = Oil fog lubricator
- D = Silencer
- E = 5/3 valve
- F = Air motor
- G = 3/2 valve

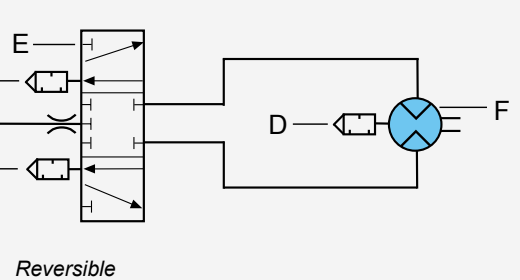
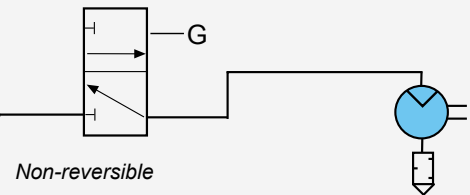
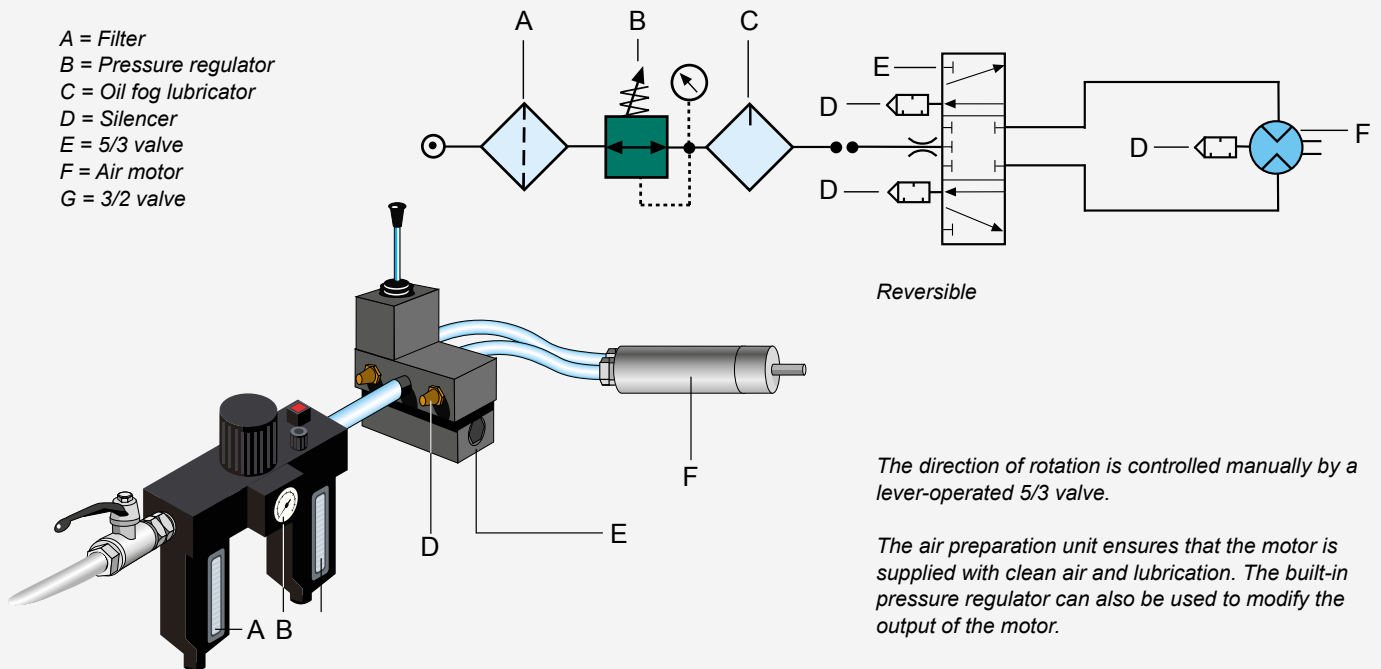

The direction of rotation is controlled manually by a lever-operated 5/3 valve.

The air preparation unit ensures that the motor is supplied with clean air and lubrication. The built-in pressure regulator can also be used to modify the output of the motor.

Appendix

Planetary gears

Planetary gears are used when small dimensions are important because they have high torque capacity for a given size. The main parts in planetary gears are the sun wheel, the planet wheels, the gear rim and the planet shaft. The planet shaft is the output shaft. The planet wheels are placed on the planet shaft. The outer part is the rear rim that has internal cogs.

The gear ratio is calculated using the formula:

$i = 1 + \frac{Z_3}{Z_1}$ where Z_1 is the number of teeth on the sun wheel and Z_3 is the number of teeth on the gear rim.

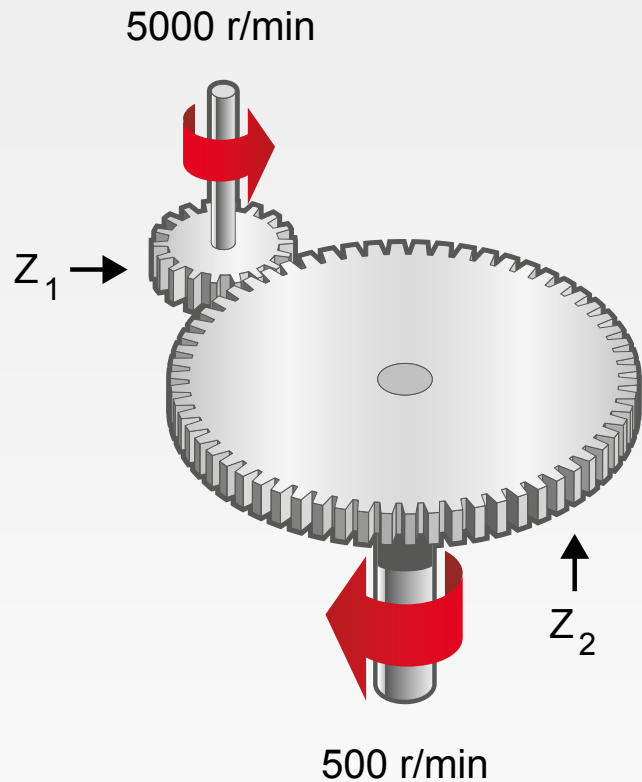

Helical gear

The helical gear is the basic gear type. A single step helical gear has two gear wheels, the primary high speed wheel, pinion, and the secondary low speed wheel. The gear ratio is defined by the number of teeth on the primary and secondary wheels. It is calculated

using the formula, $i = \frac{n_1}{n_2} = \frac{Z_2}{Z_1}$ where

i = the gear ratio,

n_1 = the primary speed,

n_2 = secondary speed,

Z_1 = number of teeth on the primary wheel

Z_2 = number of teeth on the secondary wheel.

High gear ratios require a very big secondary gear wheel. Therefore it is more practical to design the helical gears in more steps when higher gear ratios are desired.



CHICAGO PNEUMATIC AIR MOTORS:

A COMPLETE AND VERSATILE RANGE

Chicago Pneumatic offers a wide range of rotating vane air motors in stainless steel and lubrication free versions:

- Power ranging from 0.16 kW (0.21 HP) to 1.8 kW (2.45 HP)
- Most motors can be supplied as either unidirectional with a threaded shaft, or reversible with a keyed shaft. Alternative output options are also available
- **ATEX** certified for environments with potentially explosive atmospheres.

You can view our complete range on our website www.cp.com or on our online catalogue m.cp.com by **flashing this QR Code:**

You will be able to browse our air motor portfolio and for each model you can access:

- Downloadable CAD drawings in all formats to integrate into your projects
- Performance curve to determine which model to choose
- Product pictures

Also, a complete range of accessories is available to ease air motors installation.

Chicago Pneumatics' vane air motor is a comprehensive air motor system combining multiple configuration set-ups:

| | |
|--|-----------------------------------|
| Compact and well-balanced design | Resistant in hostile environments |
| Powerful stalling resistance without overheating | |



With more than **100 different motors**, the range is subdivided in **3 categories**: standard, stainless steel and low speed.

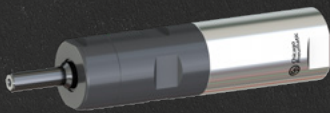

Standard air motors are compact in design, light in weight, and available with a variety of speed and torque requirements. They are suitable for building into handheld machines or any industrial equipment.

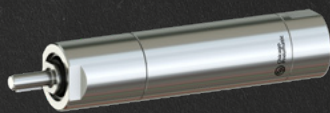

Stainless steel motors are suitable for corrosive environment applications. This would include food processing industries or chemical industries.

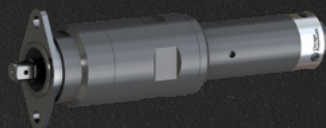

Low speed air motors offer a low costing complete solution, when an application requires low speed and low torque. The air consumption is relatively constant regardless of the load applied.

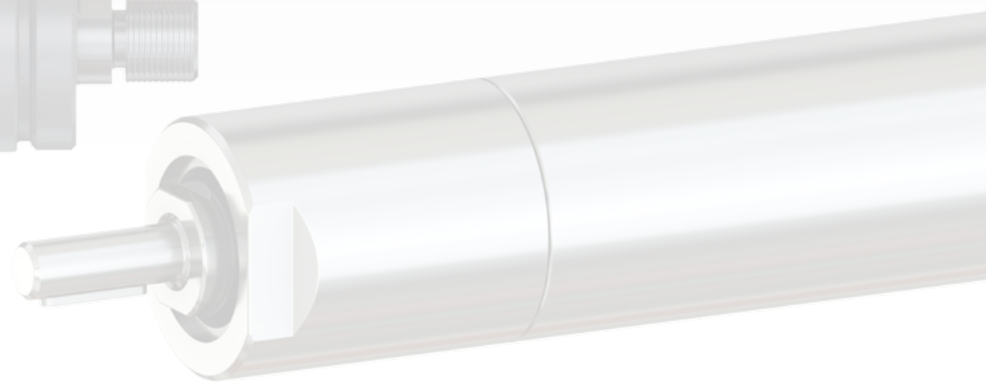
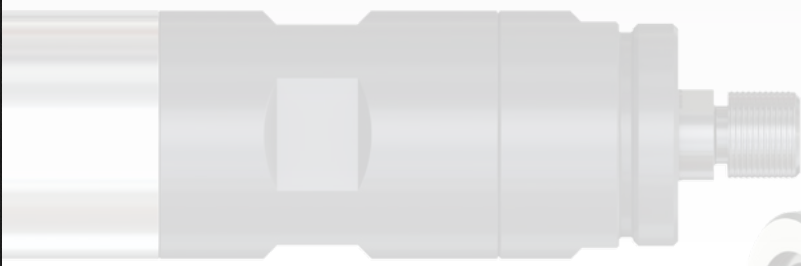
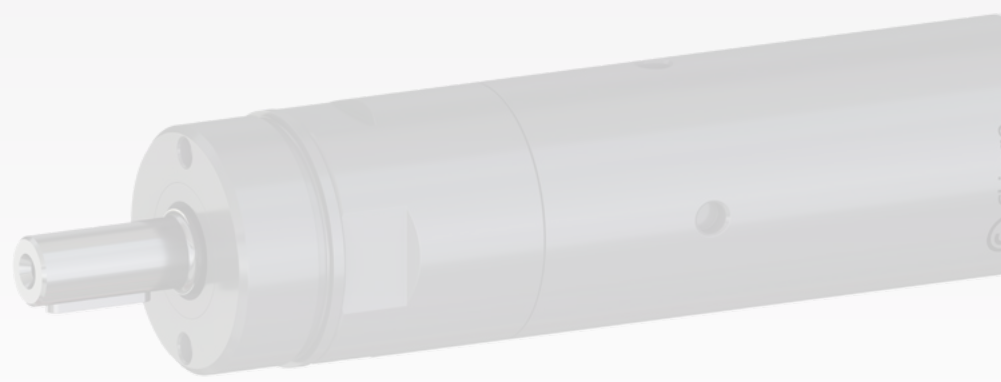
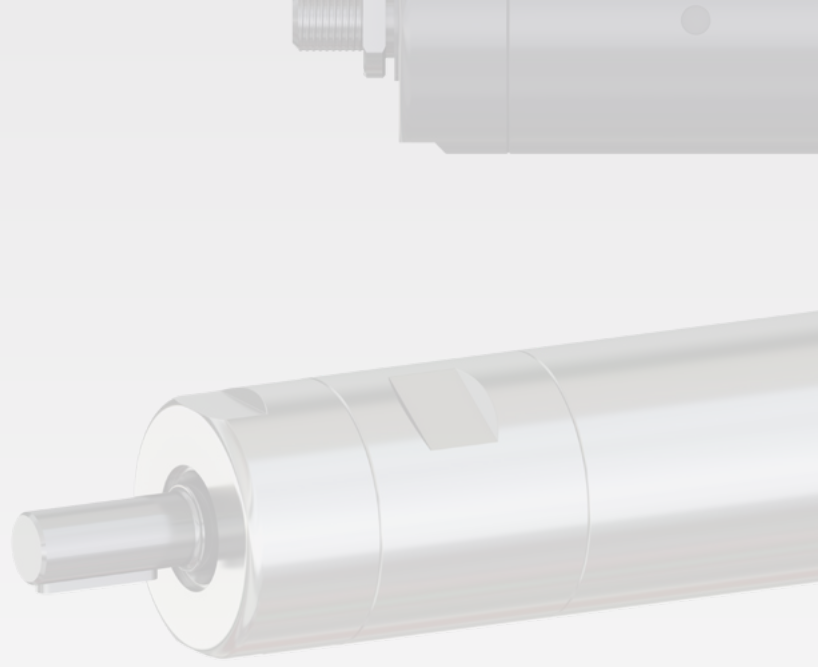

 **Chicago
Pneumatic**





Since 1901 the Chicago Pneumatic name has represented reliability and attention to customer needs, with construction, maintenance and production tools and compressors designed for specific industrial applications. Today, Chicago Pneumatic has a global reach, with local distributors around the world.

Our people start every single day with a passion to research, develop, manufacture and deliver new products that are meant to meet your needs not only today, but tomorrow as well. To learn more, visit www.cp.com.

For more information, please contact your CP partner:

Use only authorized parts. Any damage or malfunction caused by the use of unauthorized parts is not covered by Warranty or Product Liability.